

## **E. coli O157: H7 Food Detection Kit (Provided with culture media)**

### **MBT115**

#### **Description:**

The kit is developed for simple and rapid detection of *E.coli* O157:H7 from variety of food samples after enrichment according to AOAC guidelines followed by a multiplex PCR assay designed for the specific detection of the targeted organisms.

*E.coli* O157:H7 is a rod-shaped, gram-negative, aerobic and non-fermentative bacterium that causes hemolytic colitis and hemolytic uremic syndrome. *E. coli* O157:H7 is known by its somatic (cell wall) antigen (O157) and its flagella antigen (H7). *E. coli* O157:H7 is also known to produce Shiga-like toxins which cause severe symptoms. The main mode of infection is through contaminated food, untreated water and unpasteurized milk. This organism is characterized by Endotoxin shock as one of the lethal manifestation of infection. While majority of the patients recover from infection around 15% of the patients develop hemolytic uremic syndrome which could be fatal.

**NOTE: The E. coli O157:H7 Food Detection Kit is for *in vitro* use only.**

#### **Intended Use:**

The *E. coli* O157:H7 Food Detection Kit is designed for detection of specific sequence of **eaeA** gene (**482 bp**) for *E. coli* O157:H7 in various food samples. PCR testing can provide rapid, sensitive and specific detection of *E.coli* O157:H7. This kit also contains **Internal control** and **Positive control**.

**Internal control:** This is a control sequence amplified in the same reaction tube along with the target sequence (target pathogen) but detected with a different primer (i.e. Multiplex PCR). An internal control is often used to detect the failure of amplification in cases where the target sequence is not amplified.

**Positive control:** This is a control reaction using a known template (target pathogen). A positive control is usually used to check that the primers have been designed properly and PCR conditions have been set up correctly.

#### **Principle:**

HiMedia's *E. coli* O157:H7 Food Detection Kit is a Semi-Quantitative PCR Kit which allows the amplification of **eaeA** gene (**482 bp**) from *E. coli* O157:H7 using specific primers. The amplified target is detected by using agarose gel electrophoresis.

PCR is an efficient, specific way to amplify the desired small segments of the genetic material. The three steps of a PCR reaction are Denaturation, Annealing and Extension. During the Denaturation step, the double stranded DNA gets converted to single stranded DNA due to high temperatures. In the Annealing step, a set of primers specific to the genetic sequence bind the single stranded DNA. In the Extension step, the dNTPs are incorporated by the Taq Polymerase to create a new strand of the DNA which is complimentary to each of the single template strands.

Gel electrophoresis is used to analyze the amplification of desired gene region for target pathogen based on separation of DNA fragments according to their size.

**Features:**

- Fast and simple
- Sensitive and specific results
- Guaranteed reproducible results

**Storage and Shelf-life:**

The provided kit has a shelf-life of **1 year** when stored as specified on each component's label. Repeated thawing and freezing of PCR reagents should be avoided as this may reduce the sensitivity of reagents. If reagents are to be used multiple times, we recommend storing reagents as aliquots to avoid repeated freeze and thaw. Degradation of sample DNA specimens can also reduce sensitivity of the assay. HiMedia does not recommend using the kit after the expiry date stated on pack.

**Kit Contents:**

The provided Kit contains:

| <b>Components</b>  | <b>Reagents provided for 10 PR (preparations)</b> | <b>Reagents provided for 25 PR (preparations)</b> |
|--|---|---|
| Food Lysis Buffer 1 (FLB1) <b>(DS0147)</b>                     | 15 ml   | 35ml  |
| Buffered peptone water <b>(M1494I)</b>                         | 55 g  | 130 g   |
| 2X PCR Master Mix <b>(MBT061)</b>                              | 260 µl  | 650 µl  |
| Primer Mix for <i>E. coli</i> O157:H7                          | 25 µl   | 60 µl   |
| Primer Mix for Internal Control                                | 25 µl   | 60 µl   |
| Nuclease free water <b>(ML065)</b>                             | 1 ml  | 2 ml  |
| Positive control ( <i>E. coli</i> O157:H7 DNA) <b>(MBT102)</b> | 15 µl   | 35 µl   |
| Internal Control DNA   | 15 µl   | 35 µl   |
| 6X Loading Dye <b>(ML015)</b>                                  | 100 µl  | 200 µl  |
| 100 bp DNA Ladder <b>(MBT049)</b>                              | 40 µl   | 90 µl   |

**Materials needed but not provided**

- 95°C water bath or heating block.
- Tabletop Micro centrifuge (with rotor for 2.0 ml tubes)
- Micropipettes and Tips
- Incubator Shaker
- PCR Thermal Cycler (e.g. HiMedia Code: LA948, LA949, LA950)

**Enrichment of pathogens:**

In order to ensure sensitive detection of pathogens from different variety of food products by PCR, the pathogens need to be enriched in broth (Buffered peptone water: M1494I).

**Procedure:**

- Weigh 25g of material and add it to autoclaved 225 ml of the Buffered peptone water (M1494I).

- Incubate at 37°C for 16-18 hours with shaking at 100 rpm.

**Procedure for Heat Lysis of enriched Food samples.**

1. Take 1ml of the above enriched food sample in a 2ml collection tube and centrifuge at 13000 rpm for 2 minutes.
2. Discard the supernatant and re-suspended the pellet in 1ml of Food Lysis Buffer 1 (FLB1) (DS0147). Mix well by gentle pipetting.
3. Centrifuge at 13000 rpm for 2 minutes. Discard the supernatant.
4. Re-suspend the pellet in 200 µl of Food Lysis Buffer 1 (FLB1) (DS0147).
5. Heat the tube at 95°C for 10 minutes in a heating block.
6. Allow the sample to cool at room temperature (15°C-25°C). Use 5 µl of it as a template for a 50µl PCR reaction.

**General Preparation Instructions:**

- Before use, suitable amount of all PCR components should be completely thawed on ice (4°C).
- Perform the amplification reactions in a clean area.
- Use of aerosol barrier pipette tips is recommended to reduce contamination risks from extraneous DNA templates.
- Extract and store positive control material (if used) separately from all other reagents to avoid contamination and add it to the reaction mix in a separate area.
- Centrifuge the components briefly once thawed.

**Preparation of PCR Reaction Mixture**

Add 25 µl of 2X PCR Master Mix (**MBT061**) in a PCR tube



In the same tube, add 2 µl of *E. coli* O157:H7 primer mix + 2 µl internal control primer mix (10 pmoles concentration provided)



Add 5µl of **template DNA** (extracted DNA from heat lysed enriched food sample) and add 1µl of **Internal Control DNA** (provided)



Add nuclease free water (**ML065**) to make the final volume to 50 µl



Centrifuge the tube briefly at 6000 rpm for 10 seconds.



Place the tubes in the PCR machine and set the recommended PCR program. (mentioned below )



Interpret the data using Agarose gel electrophoresis

**NOTE: (Optional) – The user can also set up an additional PCR reaction containing Positive Control DNA (provided) in a separate tube.**

**2. Recommended PCR program:**

1. Initial denaturation : 94°C for 10 minutes
2. Cycling Parameters (No. of cycles: 30)
  - Denaturation : 94°C for 30 seconds
  - Annealing : 56°C for 30 seconds
  - Extension : 72°C for 30 seconds
3. Final Extension : 72°C for 10 minutes

**3. The PCR products can be kept at 4°C overnight or frozen at –20°C for long-term storage.**

**4. *E. coli* O157:H7 PCR Assay Results Interpretation**

- For PCR data analysis, load 10 µl of amplicon on a 1.5% Agarose gel along with 1 µl of 6X DNA loading dye (ML015).
- Load 3 µl of 100 bp DNA ladder (MBT049) in separate well.

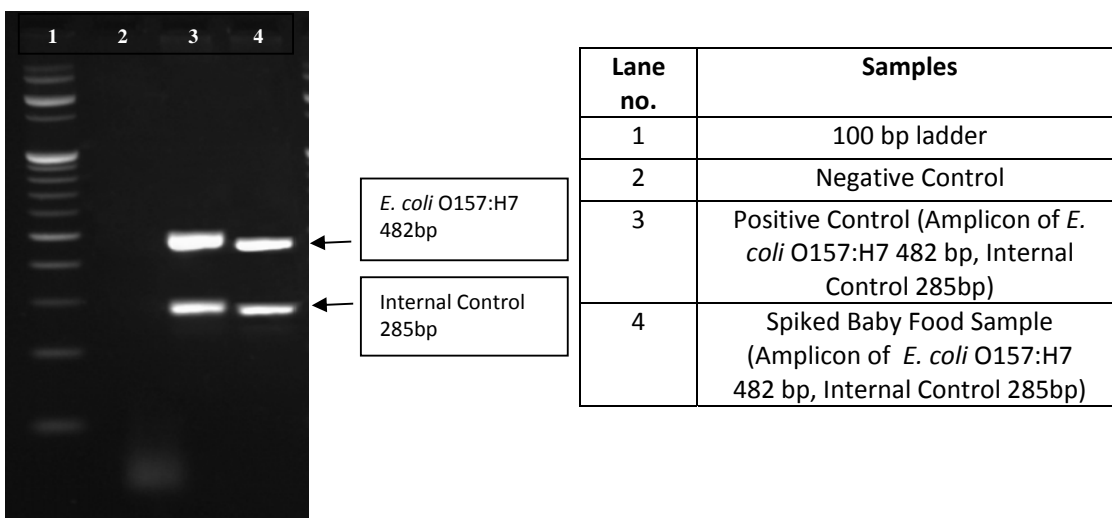

Gel image representing amplification of eaeA gene target sample of *E. coli* O157:H7 with positive control (482bp) and Internal Control (285bp)

**Specifications:-**

| Organism Targeted  | Scope (Matrices) |
|--------------------|------------------|
| <i>E.coli</i> O157 | Butter           |
|                    | Egg              |
|                    | Milk             |
|                    | Packaged Drinks  |
|                    | Milk powder      |
|                    | Baby Food        |

**Sensitivity:** The kit can detect 1 colony forming unit (cfu) per 25 grams of food sample.

**Quality Control:**

Each lot of HiMedia E. coli O157:H7 Food Detection Kit is assayed for contaminating endonuclease, exonuclease and non-specific DNase activities. Functionally tested for DNA amplification.

**Troubleshooting Guide:**

| Sr. No. | Problem                           | Cause                       | Solution  |
|---------|-----------------------------------|-----------------------------|---|
| 1.      | No amplification                  | Degraded samples            | 1. Check the integrity of DNA using agarose gel electrophoresis.<br>2. Use freshly prepared DNA to ensure the availability of intact template sequence for efficient amplification. |
|         |                                   | Error in protocol setup     | Verify that the correct reagent volumes, dilutions and storage conditions have been used.   |
|         |                                   | Error in reaction set-up    | Prepare large volume reaction mix, vortex thoroughly and aliquot appropriately into reaction tubes.   |
| 2.      | Variability between replicates    | Air bubbles in reaction mix | Briefly centrifuge reaction samples/plate prior to running on a PCR machine.  |
|         |                                   | Pipetting error             | Replicates can show increased variation due to poor laboratory techniques or imprecise pipettes.  |
|         |                                   | Reagents contaminated       | 1. Replace all critical solutions.<br>2. Repeat the analysis of all tests with fresh aliquots of critical reagents.   |
| 3.      | Amplification in negative control | Reagents contaminated       | 1. Replace all critical solutions.<br>2. Repeat the analysis of all tests with fresh aliquots of critical reagents.   |

**Safety Information**

The E. coli O157:H7 Food Detection Kit is for laboratory use only, not for drug, household or other uses. Take appropriate laboratory safety measures and wear gloves when handling.

**Product Use Limitation & Warranty**

HiMedia guarantees the performance of product in the manner described in the product literature. E. coli O157:H7 Food Detection Kit is designed and sold for research and *in vitro* purposes only. No claim or representation is intended to provide information for the diagnosis, prevention, or treatment of a disease.

All due care and attention should be exercised in the handling of the products. We recommend all users of HiMedia products to adhere to the NIH guidelines that have been developed for recombinant DNA experiments or to other applicable guidelines.

**Technical Assistance**

At HiMedia, we pride ourselves on the quality and availability of our technical support. For any kind of technical assistance, mail at [mb@himedialabs.com](mailto:mb@himedialabs.com).



Consult instructions for use



Do not use if package is damaged



HiMedia Laboratories Pvt. Limited,  
Reg. Off: 23 Vadhani Industrial Estate,  
LBS Marg, Mumbai - 400086,  
India Works: B/4-6, M.I.D.C., Dindori,  
Nashik, India (or respective plant address)  
Customer Care No: 022-6116 9797  
[www.himedialabs.com](http://www.himedialabs.com)

PIMBT115\_0/0317

MBT115-01

**Disclaimer :**

User must ensure suitability of the product(s) in their application prior to use. Products conform solely to the information contained in this and other related HiMedia™ publications. The information contained in this publication is based on our research and development work and is to the best of our knowledge true and accurate. HiMedia™ Laboratories Pvt Ltd reserves the right to make changes to specifications and information related to the products at any time. Products are not intended for human or animal diagnostic or therapeutic use but for laboratory, research or further manufacturing use only, unless otherwise specified. Statements contained herein should not be considered as a warranty of any kind, expressed or implied, and no liability is accepted for infringement of any patents.